



**BASIS FOR BEARING**

BEARINGS AND DISTANCES, SHOWN HEREON, ARE DERIVED FROM GPS OBSERVATIONS BASED ON GRID SOUTH, OHIO STATE PLANE COORDINATE SYSTEM, SOUTH ZONE, NAD83 (2011) WITH THE CENTERLINE OF EXISTING RIGHT OF WAY OF TAYLOR ROAD (CR-205) HAVING A BEARING OF S86°29'30"E.

0 150  
SCALE:  
1" = 150'

# K C REAL PROPERTY INVESTMENTS, LLC. BOUNDARY SURVEY

TOWNSHIP OF JEFFERSON  
CITY OF BLACKLICK  
FRANKLIN COUNTY, OHIO  
SECTION 4, TOWNSHIP 1, RANGE 16  
UNITED STATES MILITARY LANDS

**ACREAGE BREAKDOWN:**

TOTAL ACREAGE: 2.874 ACRES  
PARCEL 170-000841-00: 1.634 ACRES  
PARCEL: 170-000027-00: 1.241 ACRES (PRO ACREAGE = 0.092 ACRES)

**LEGEND**

- IRON PIN FOUND (AS NOTED)
- ⊙ PIPE FOUND (AS NOTED)
- ½" IRON REBAR W/ "DLZ" CAP SET
- ⊙ M.N.S. MAGNETIC NAIL SET
- ⊙ FRANKLIN COUNTY ENGINEER STANDARD COUNTY MONUMENT (AS NOTED)
- (T) TOTAL
- P — PROPERTY LINE
- EX U — EXISTING UTILITY EASEMENT
- EX SH — EXISTING HIGHWAY EASEMENT
- EX R/W — RIGHT-OF-WAY LINE
- — ROAD CENTERLINE
- X — EXISTING FENCELINE (AS NOTED)
- - - EXISTING GRAVEL/CONCRETE DRIVE
- F.C.E. FRANKLIN COUNTY ENGINEER
- F.C.G.S. FRANKLIN COUNTY GEODETIC SURVEY
- P.O.B. POINT OF BEGINNING

**SURVEY CERTIFICATION**

THIS BOUNDARY SURVEY WAS PREPARED IN ACCORDANCE WITH CHAPTER 4733-37 OF THE OHIO ADMINISTRATIVE CODE. I CERTIFY THAT THIS PLAT OF SURVEY WAS MADE UNDER MY DIRECT SUPERVISION AND IS BASED ON AN ACTUAL FIELD SURVEY, DATED FEBRUARY, 2024, ALL MONUMENTATION IS OR WILL BE SET AS SHOWN.

THIS SURVEY WAS PERFORMED WITHOUT THE BENEFIT OF A TITLE POLICY. ALL OWNERSHIP SHOWN IS BASED UPON RECORDED DATA ACQUIRED AT THE TIME OF SURVEY. NO GUARANTEE IS PLACED UPON ACTUAL OWNERSHIP OF ANY PROPERTY.

EASEMENTS MAY EXIST ON SUBJECT PROPERTY THAT WOULD BE REVEALED IN A TITLE EXAMINATION.

*Samuel L. Stiltner* 4/15/2024  
DATE:  
SAMUEL L. STILTNER  
PROFESSIONAL SURVEYOR S-8364

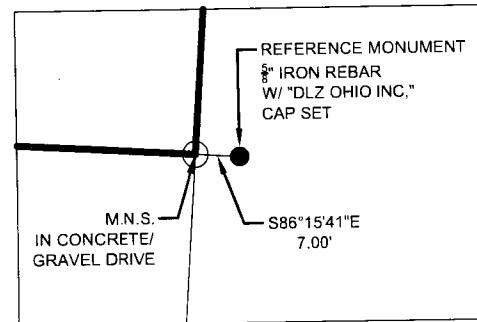
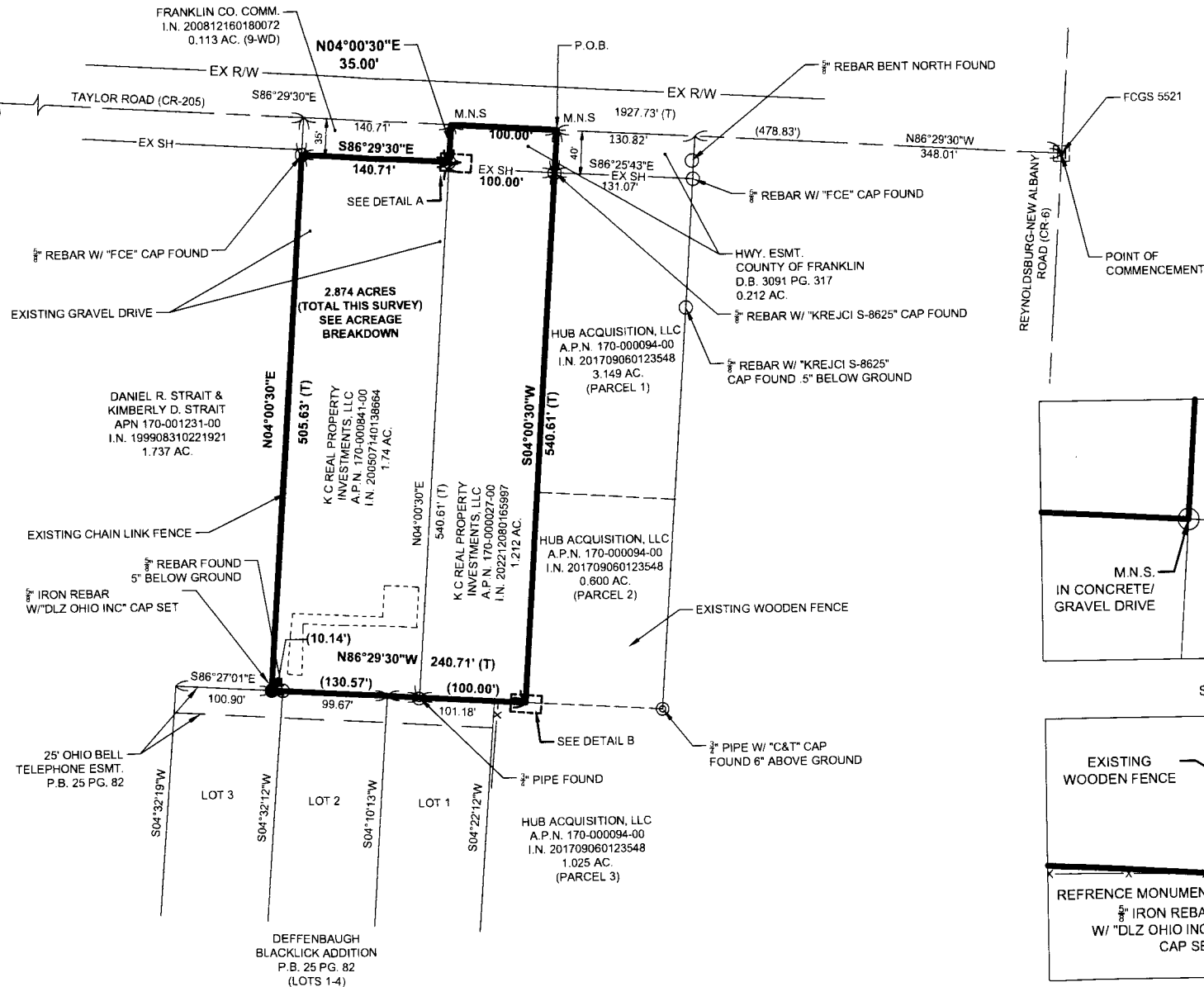

DETAIL A  
SCALE 1:30

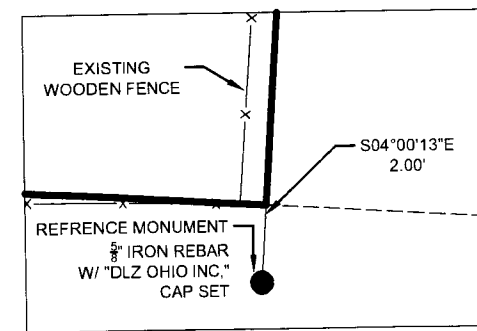

DETAIL B  
SCALE 1:5

**RECEIVED**

APR 22 2024

FRANKLIN COUNTY ENGINEER  
BRAD FOSTER, P.E., P.S.



6121 HUNTLEY RD, COLUMBUS, OHIO 43229-1003  
TELEPHONE (614) 888-0040 FAX (614) 436-0161