

O-34-F  
Jackson Twp.

RRS. FD.  
NE. COR.  
28.5 AC.

Split.

C/L BORROR ROAD

RRS FD.  
NW. COR.  
28.5 AC.

MAG. NAIL  
SET

3/4" I.P. FD.  
@ 25.00'

N 72° 30' 00" E  
214.00'

632.61'

3/4" I.P.  
SET

3/4" I.P.  
SET

N 02° 58' 33" E  
90.00'

57.98'

HOUSE  
1401

GARAGE

FRAME  
BARN

2.0257  
ACRES

MILDRED CHRISTIAN  
26.59 AC.  
OR. 16047-J-08

MARK R. & LESLIE R. HARBOLD  
5.002 ACRES  
DB. 3578 PG. 416

434.00'

N 12° 59' 39" W

60' INGRESS & EGRESS EASEMENT  
EX. 12' LANE & EASEMENT

S 01° 36' 09" W — 580.00'

3/4" I.P. SET

9.5.00' N 88° 23' 51" W

3/4" I.P. SET

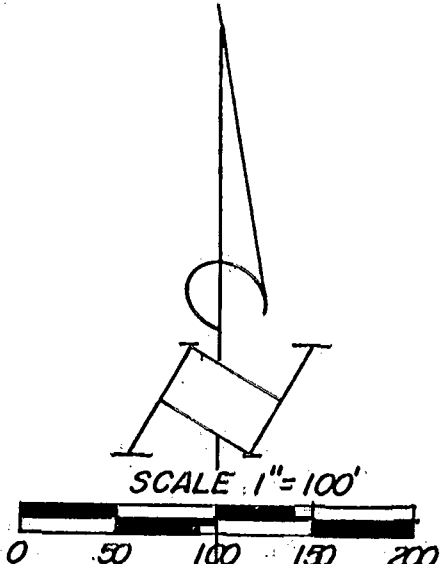

SCALE 1" = 100'  
BASIS OF BEARINGS:  
C/L BORROR ROAD AS  
N 72° 30' E FROM DEED  
OR-16047-J-08

SURVEY OF 2.0257 ACRES  
VMS. 6115, JACKSON TOWNSHIP,  
FRANKLIN COUNTY, OHIO:  
for  
PERRY & MILDRED CHRISTIAN

3/4" I.P. FD.



**Louis F Haines**

354 Kessler Street  
Groveport, Ohio 43125  
Phone 837-2181

I HEREBY CERTIFY THE PLAT SHOWN HEREON  
IS CORRECT AS SURVEYED BY US.  
DATE: April 19, 2000  
SIGNED: [Signature]

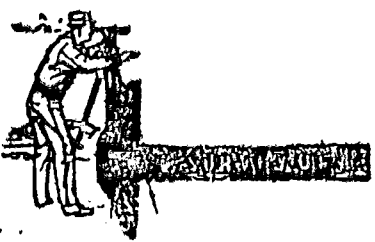

81606725  
81606700